

Technical Notes

1. What is the general lead-time of the products?

Generally, if the crystal needed has raw material in stock, the lead-time may be sooner than expect. If the parts or raw material are not available and need to be made from scratch. The general lead-time is as follow:

Crystal 3 ~ 4 weeks

Clock Oscillator 6 ~ 8 weeks

TCXO 8 ~ 12 weeks

VCXO 6 ~ 10 weeks

VCTCXO 8 ~ 12 weeks

(*Lead-time may vary from time to time. Please double confirm.)

2. Since the lead-time is set, what about sampling?

For prototyping, we normally would search our inventory for a similar part that matches the custom part's requirement. The manufacturing of the custom part will begin the same time if requested.

3. What basic information to provide when ordering a crystal?

Generally we request the customer to provide the nominal frequency, type of cutting angle (AT/BT), holder or package type, resistance (ESR), frequency tolerance, frequency stability, load capacitance, operating temperature range, drive power, aging, etcK Customer can also specify other specific spec or requirement, if any, when placing orders.

4. What is the main difference between frequency tolerance and frequency stability?

Sometimes the "reference" frequency may be referred to the nominal (spec) frequency, if it is so specified by customers.

The frequency stability is usually stated in parts per million (ppm).

The frequency tolerance of a crystal is defined as the maximum allowable frequency deviation, in ppm, from the nominal (spec) frequency at a specified temperature, usually +25XC (2XC)

5. What happens to the performance of a crystal when it's not operating within the temperature range stated in the specification?

The crystal performance will be affected. We highly do not recommend such to take place. It can cause the frequency of the crystal to drift. Worse scenario is it may cause malfunction of customer circuit.

6. What is AT or BT Cuts?

Crystal carries, mainly, its "frequency stability" characteristics as a result of how the quartz bars are cut, in a certain pre-oriented angle, into crystal wafers. Today the most popular and widely used one is the AT-Cut.

The AT-cut has a cutting angle of around $35^{\circ}15'$ to the Z-axis in the negative Y-axis direction, as compared to a -45° to the Z-axis in the positive Y-axis direction for the BT-cut. For ease of understanding, a graph of the two cuts are shown below.

Generally the BT cut blanks are thicker than the AT Cut one at the same frequency, so higher frequency can be achieved using BT cut.

One major difference between AT-cut and BT-cut is the frequency stability characteristics. Please also refer to the temperature coefficient curves of the two cuts below.

Quartz Cut Angle	The Range of Freq.	Frequency(MHz)
AT (Fundamental)	3.5~30	$1.67 \times 1/t$
AT (3rd. O. T.)	30~100	$5.01 \times 1/t$
AT (5th. O. T.)	100~150	$8.35 \times 1/t$
AT (7th. O. T.)	150~200	$11.69 \times 1/t$
BT (Fundamental)	7~38	$2.56 \times 1/t$

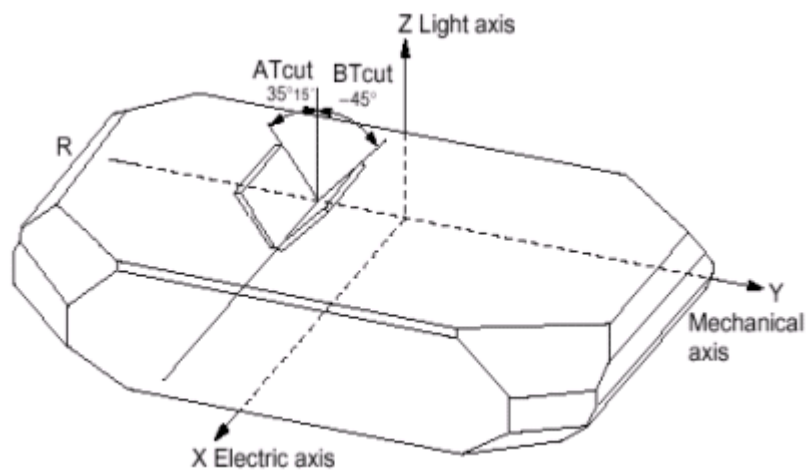

AT-Cut & BT-Cut Angles

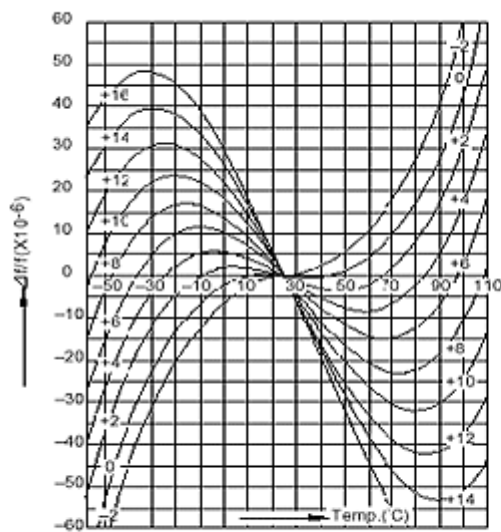

AT-Cut
Temperature Coefficient

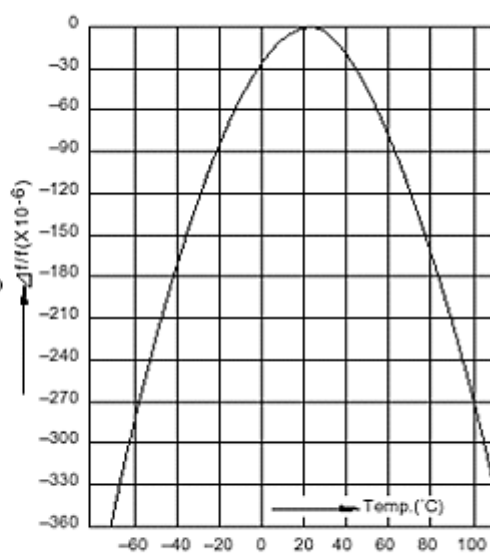

BT-Cut
Temperature efficient

7. Does SJK make it's own crystal or do you source and mark the parts with your name on it?

SJK is an end-to-end frequency quartz manufacturer. By saying end-to- end, we mean not only do we make our own crystals, we also grow our own high Q crystal bars.

8. What is the aging of the crystal?

Aging is the change in frequency of a crystal over time. Aging can be in the positive or negative direction.

Aging effect contributes to the overall frequency drift of the oscillator that the crystal is used in.

Aging will be mainly affected by two important factors, namely, contamination and stress. Experiment proves that contamination on crystal wafer usually causes a negative frequency shift, whereas excessive stress often results in positive frequency drift.

When crystal wafer is mounted on a holder (base), it could very possibly be pushed, pulled, or twisted by the mounting structure. This causes stress on the crystal wafer. Such stress will be released or relaxed with time and thus results in positive frequency shift. When assembling the crystal unit, proper mounting method of wafer and using the proper holder (base) will help eliminate or reduce the unwanted stress. For a finished crystal, thermal cycling can be used to expedite the process of exercising & relaxing the mounting stress.

Contamination on wafer could happen in various stages of crystal production. Contamination that attaches itself to the surface of wafer causes negative frequency shift because of mass loading effect. Contamination should be minimized by improving cleanliness of manufacturing process as well as cleanliness of wafer in every production step.

Crystals can be "pre-aged", to a certain degree, to minimize the effects of aging. Because aging characteristics tend to follow a logarithmic curve, most of the aging of a crystal will occur in the first year

of its life. The rate of change of crystal frequency is relatively more or faster during the first year than the second year and beyond.

9. What is pull-ability?

The pull-ability of a crystal is a measure of frequency change as a function of load capacitance.

Circuit designer can accomplish an operating frequency range by changing or varying the load capacitance of the crystal. The operating frequency range is determined by the pull-ability of the crystal at a given (varying) range of the load capacitance.

10. What are spurious frequencies?

It is possible for a crystal to vibrate at frequencies that are not related to its fundamental nor overtone frequencies. Such unwanted frequencies are referred to as spurious.

Effects of spurious frequencies can be suppressed in the crystal design & manufacturing stage by changing crystal wafer size, electrode pattern design, and adjustment of metalization on crystal wafer.

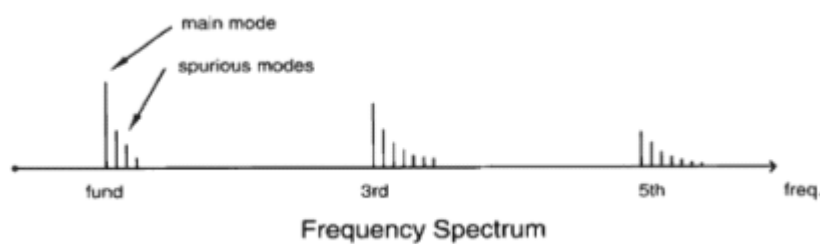

11. What will be the effect of spurious frequencies?

When signal level of spurious mode gets as strong as the main mode, the oscillator may run on the spurious mode instead of the main mode. Such a phenomenon is called mode hopping.

Spurious mode is usually defined as either a resistance ratio or dB suppression to the main mode. A resistance ratio of 1.5 or 2.0 to that of the main mode is needed to avoid mode hopping for most oscillators. This would be approximately equivalent to a -3dB to -6dB signal suppression over the main mode.

12. What happens if I operate a crystal over its maximum drive level spec?

An over-drive crystal may cause its frequency and resistance to change, in many cases, to a higher value. This would mean changes in crystal electrical characteristics. Sometimes activity dips could thus happen. It could also result in a broken crystal wafer due to too much power over-drive for too long an interval of time.

A common phenomenon in frequency shift over high drive power is depicted below.

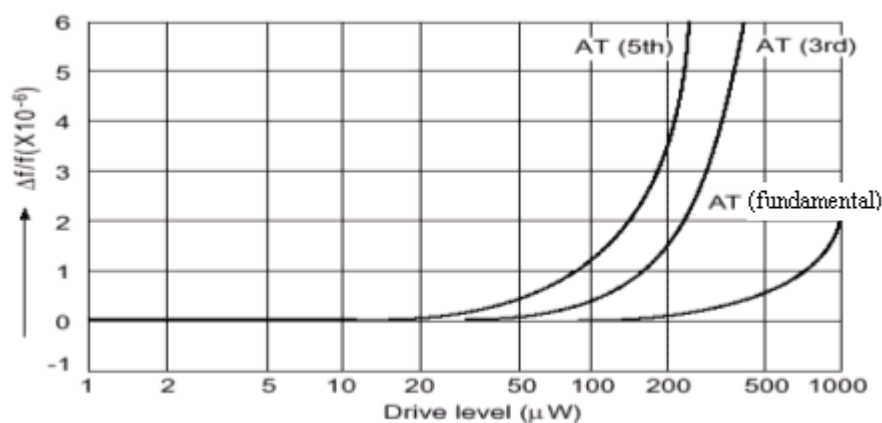

13. What is an activity dip and do I need to worry about them?

Activity dips are symptoms of discontinuity in frequency or resistance of a crystal over its operating temperature range. Sometimes it is also referred to as "non-linearity".

Depending on the real circuit implementation, different circuit designs may tolerate different levels of crystal activity dips.

14. Why don't HC-49S crystals pull as much as HC-49U crystals?

Pull-ability of a crystal usually has to do with the electrode size which forms on the crystal blank. A bigger size crystal blank of course can accommodate a larger electrode. HC-49S has a smaller dimension in blank than HC-49U.

Larger electrode would typically provide a wider frequency pulling range when crystal is placed in series with a given load capacitance in the oscillation circuit.

15. What is trim sensitivity (T.S.)?

Trim sensitivity is the incremental frequency change of a crystal for an increment change in load capacitance. It is often expressed in ppm/pF. A typical mathematical approximation for trim sensitivity shows T.S. changes as CL varies:

$$T.S. = C1 / [2 (Co+CL)]$$

16. What are the motional and shunt capacitances of a crystal unit?

Motional capacitance (C1):

It is the capacitance residing in the motional (series) arm of the ideal crystal equivalent circuit model.

Shunt capacitance (C0):

It is the static capacitance between the crystal electrodes, together with the stray capacitance of the mounting system.

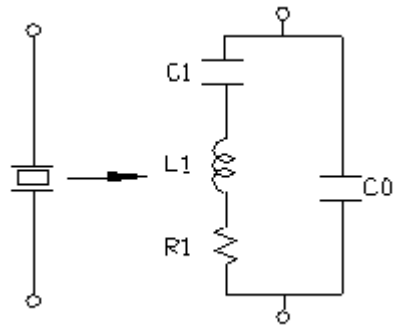

17. What are the differences between AT-cuts and AT-strip cuts?

Please also refer to FAQ No. 6 for explanation on AT-Cut.

AT-strip cut is usually referred to the rectangular crystal blanks which have the AT-Cut angle.



AT-Cut in Rounded Blank



AT-Strip Cut in Rectangular Blank

18. What is the difference between a "crystal" and a "strip resonator"?

A strip resonator is a crystal in which an AT-strip cut blank is used and mounted.

A strip resonator is more sophisticated in its electrical characteristics than a crystal that utilizes a round blank. More skills and cautions are required in the design for a strip resonator to achieve the desired electrical characteristics.

19. What is load capacitance?

Crystal by its function is to be placed and work in an oscillation circuit for generating a desired oscillation frequency. When a crystal sits in an oscillation circuit, it sees a "load capacitance" at the two terminal leads of the crystal. Such a load capacitance is the equivalent capacitive effect of the entire oscillation circuitry that appears at or presents to the crystal.

Thus, the nominal spec frequency of a crystal is often defined as FL which stands for "load resonant frequency" at a given capacitance value. This capacitance value is to reflect the actual "load capacitance" presented to the crystal when it is placed and work in a real oscillation circuit.

A crystal with zero (0) load capacitance number has its resonate frequency designated as Fr, series resonant frequency.

20.What are piezoelectric characteristics of a quartz crystal unit?

Quartz is a device that carries the piezoelectric characteristics. The piezoelectric characteristics of a quartz crystal is briefly explained below:

If a piezoelectric quartz crystal has electrodes plated on opposite faces and if a potential is applied between these electrodes, forces will be exerted on the bound charges within the crystal. If the crystal is properly mounted, deformations take place within the crystal, and an electromechanical system is formed which will vibrate at a resonant frequency when properly excited.

21.what is the crystal electrode?

Each crystal has a blank inside the enclosure. There are two electrodes on the blank, one on each side of the blank. The electrode is a round or rectangular area covered by a thin layer of silver (in some designs, it could be gold/Ag too). In crystal production, the electrodes were formed by deposition of silver onto the blank in high vacuum. This process is also known as "plating".

Forming the electrode on the blank is actually a process of plating (depositing) silver onto the blank. Plating is done in two steps, base plating and fine plating. Base plating is performed in a batch mode by which a bunch of blanks are plated at the same time in one vacuum chamber. Base plating usually brings the blanks to a frequency range that is roughly 500 to 1,000 ppm (plate back range) above the target

frequency. Fine plating is then done one by one and it will precisely take each blank to within, for example, +/- 30 ppm tolerance of the spec (target) frequency.